

Bike Storage

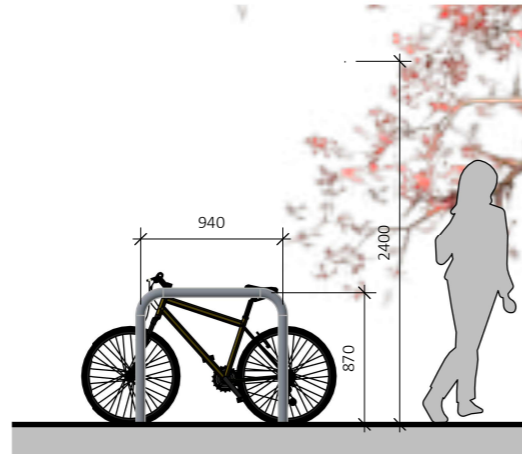

2 Front Elevation
1 : 50



4 Cross Section A-A
1 : 50

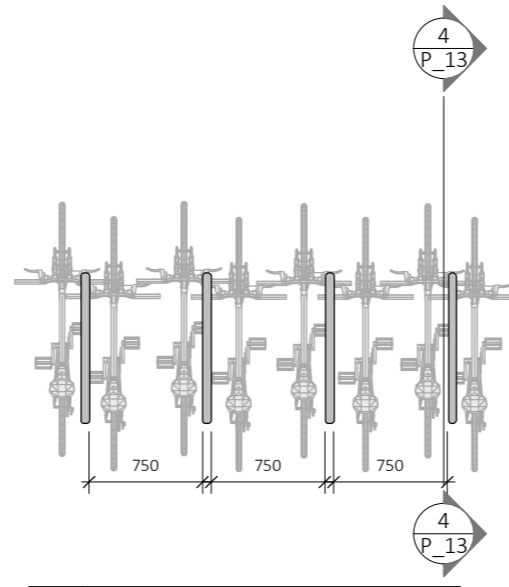

1 Ground Floor Plan
1 : 50



PLEASE NOTE:
Copyright of this drawing is reserved by BRH Architecture and Engineering.
All construction methods, materials, installations to be in accordance with all building regulations and codes of practice at the time of construction.

All sub-contractors are ultimately responsible for ensuring compliance with regulations within their own trade.

The user of this drawing shall cross-check dimensions shown on this drawing with relevant dimensions shown on other drawings issued by BRH Architecture and Engineering and by other design consultants relevant to the project prior to any fabrication or construction on site. All errors, omissions and discovered inconsistencies to be reported to the BRH Architecture and Engineering immediately.

All trades to check dimensions on site prior to fabrication.

Drawings show design intent only.

Do not scale dimensions from the A3 drawing.

This drawing is specific to the job outlined in the title box below.

Bin Storage

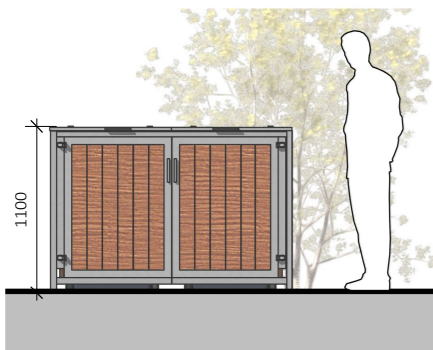

3 Bins Front Elevation
1 : 50

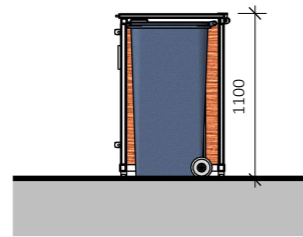

6 Cross Section B-B
1 : 50

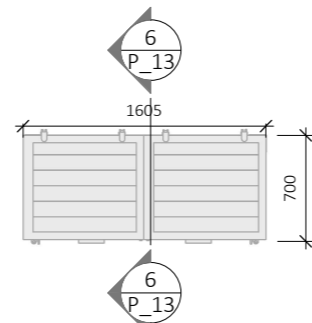

5 Bins Roof Plan
1 : 50

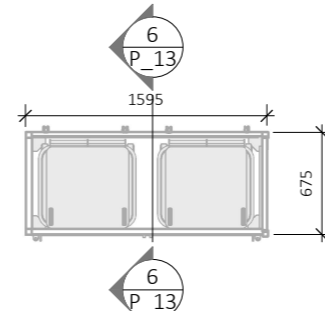

8 Bins Floor Plan
1 : 50



1	Issued For Planning	01/02/21	JP
REV	DETAIL	DATE	BY



Phoenix House, Monahan Road, Cork.
T-021 2376150 E: info@brh.ie

CLIENT: Eoin Sheehan

PROJECT: Residential Development
Monacnapa, Blarney,
Co. Cork

Drawing: Bike Storage, Bin Storage -
Plans, Sections & Elevations

Drawn By: OC	Checked By: MB	Drawing Number: 21001	Revision: P_13	Stage: 2	PA
SCALE: 1 : 50					